

## **BNP 721 modified blast cabinet**

Modifiziert BNP 721 blast cabinet with enlarged blast room and powered turntable.

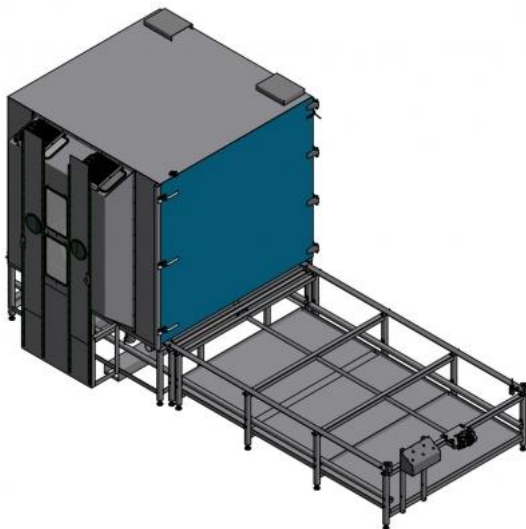

Application	Blasting of large and heavy workpieces
Equipment solution	BNP 721 with enlarged working chamber (2.200 x 2.200 x 2.000mm) Powered turntable
Application advantage	Large and heavy workpieces can be easily loaded onto the truck from the outside of the cabinet and carried into the blast chamber. In the cabinet inside the workpieces are moved by a powered turntable.
Special Options	Workpieces up to Ø 2000mm and maximum load up to 2000kg
Media reclaimer	Cyclone
Dust collector	MBX cartridge filter with 4 cartridges
Blast system	Pressure blast