

BNP 220 Tripple blast cabinet

TA08070

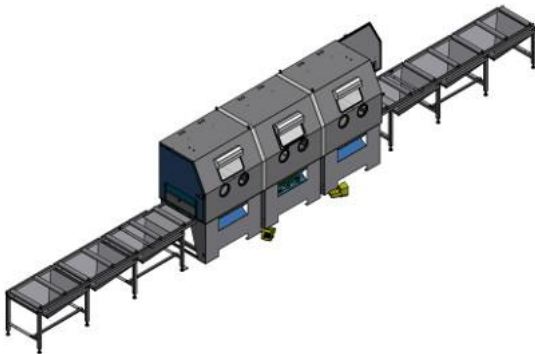

Continous tripple blast cabinet with integrated roller track and sliding gate.

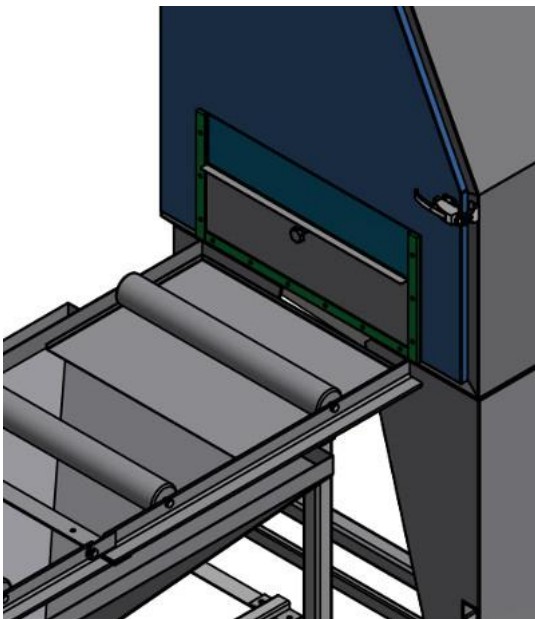

Application	Blasting of long pipes and profiles
Equipment solution	3x merged BNP 220 blast cabinet Roller track Sliding gate for side doors (650 x 150mm) Blast pot with 2 outlets (2x blast nozzle) Rubber curtain (wear protection)
Part Handling	Due to the sliding gate, the workpieces can be conveyed into the blast chamber during the blast process. In the blast chamber the operator has three different workplaces with two blast nozzles to blast the workpiece.
Application advantage	Constant conveying of long workpieces that are larger than the acutal blast cabinet.
Special Options	Extra long work space with three work stations and two blast nozzles.
Blast nozzle	2x pressure blast nozzle
Media reclaimer	Cyklone - 1200Cfm, PU coated
Dust collector	MBX cartridge filter with 4 cartridges
Blast system	Pressure blast system