

## **A-200 blast cabinet for lampshades**

TA06073

Automatic blast cabinet with integrated blow off chamber for serial production of lampshades.

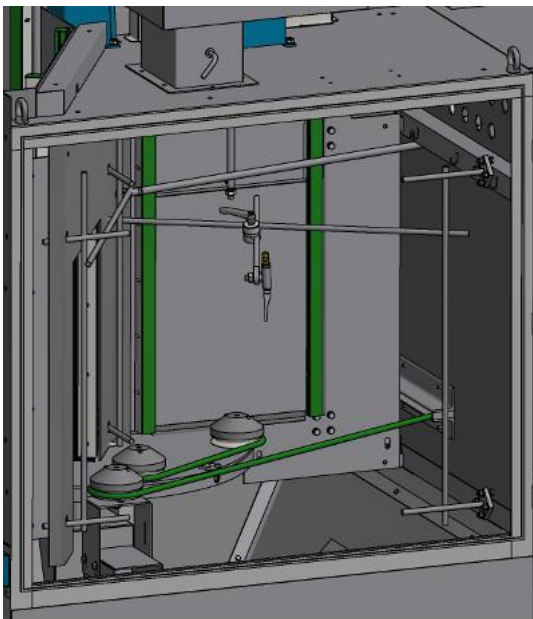

Application	Blasting of lampshades for surface preparation before metallization
Equipment solution	3 satellites (workpiece holder) 5 blast guns
Part Handling	The lampshades will be fixed on the workpiece holder and guided automatically through the cabinet. In the first chamber the workpieces will be automatically blasted by five blast guns, in the second chamber remains of the blast media on the workpiece will be blown off. Afterwards the lampshades exit the chamber for further processing.
Application advantage	Automatic blasting and blowing off of the workpiece for reproducible results in serial production
Abrasive media	Glass beads (0,2 - 0,8mm) Aluminum oxide (0,2 - 0,8mm)
Media reclaimer	Cyklone
Dust collector	MBX cartridge filter with 4 cartridges
Blast system	Injectorsystem

**Global engineering -  
Trusted solutions**

**CLEMCO<sup>®</sup>**  
INTERNATIONAL

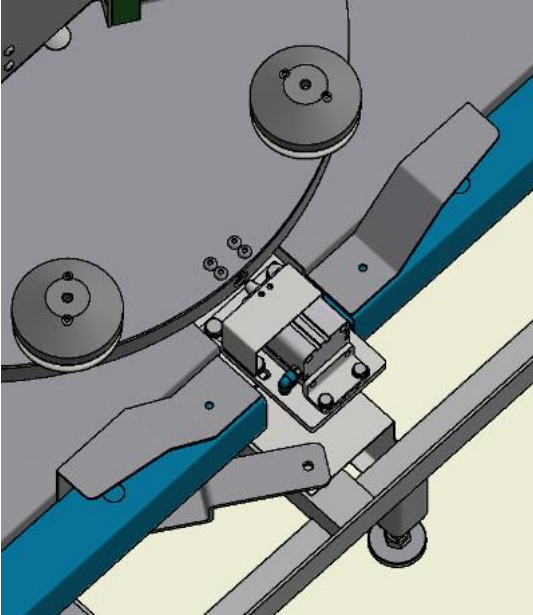

**Clemco**  
International GmbH

[www.clemco-international.com](http://www.clemco-international.com)