

A-200 blast cabinet for pans

TA13064

A-200 automatic blast cabinet to blast and blow off pans.

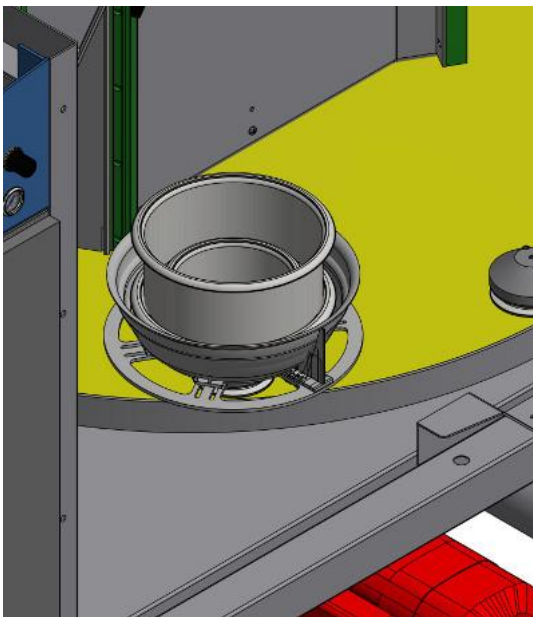

Application	Automatic blasting and blowing off of pans with maximum 5kg in one cabinet
Equipment solution	PLC control panel 4 injector blast guns
Part Handling	The workpieces will be fixed on a clamping fixture at the front of the cabinet. The fixture with the workpiece is automatically guided through the blast cabinet where it gets blasted by 4 blast guns and in a second chamber it will also be blown off automatically. Afterwards the workpiece exits the chamber.
Application advantage	Automatic blasting and blowing off of the workpiece, while the operator is loading the clamping fixtures.
Production rate	around 50 pans per hour
Abrasive media	White Aluminum Oxide
Blast nozzle	4x 9,5mm boron carbide injector nozzle
Media reclaimer	Cyclone with 1200cfm
Dust collector	MBX cartridge filter with 4 cartridges
Air requirements	15m ³ /minute at 6 bar
Blast system	Injectorsystem
Electrical requirements	3x 400V/50Hz 6kW total consumption